

Therec Engineering & Consulting Co., Ltd.

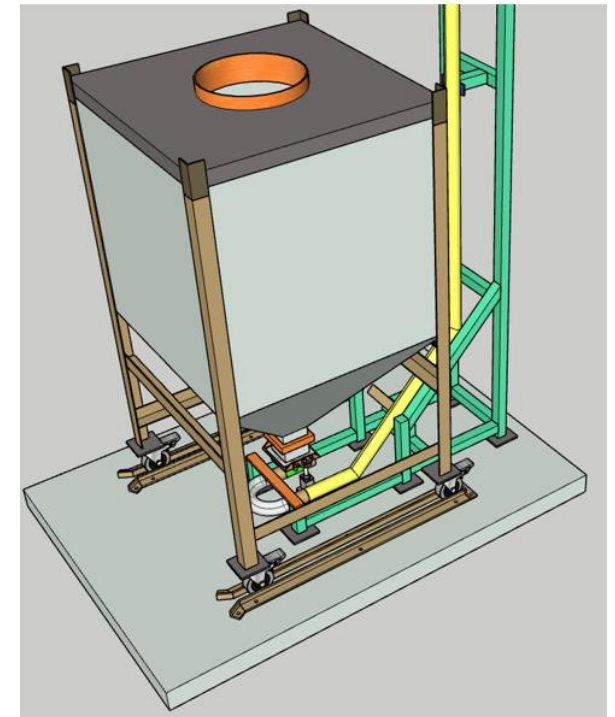
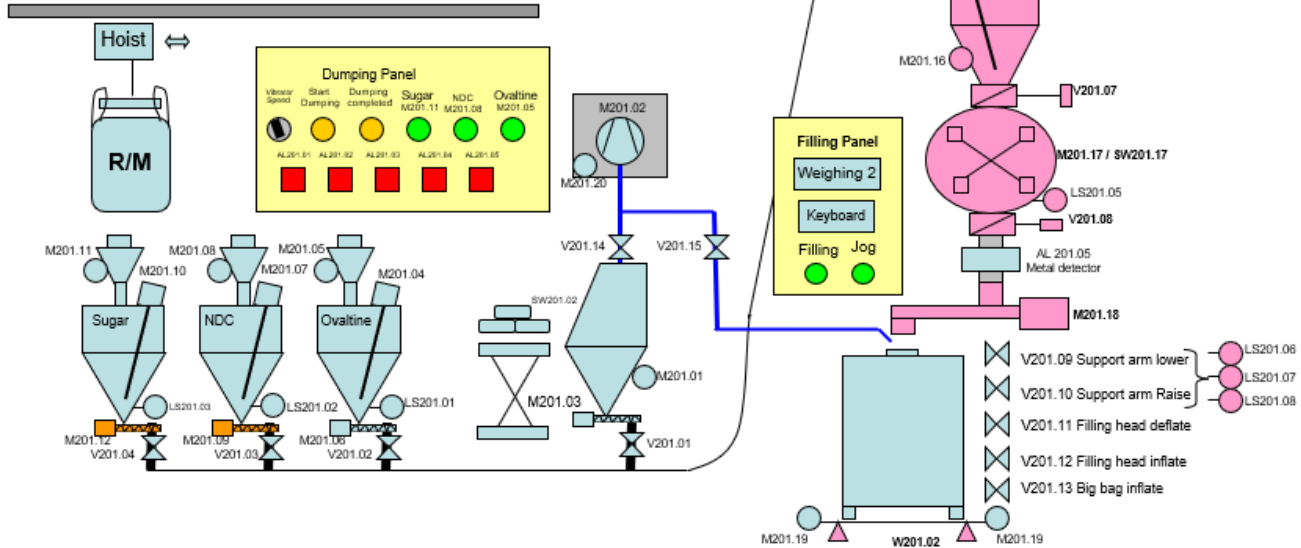
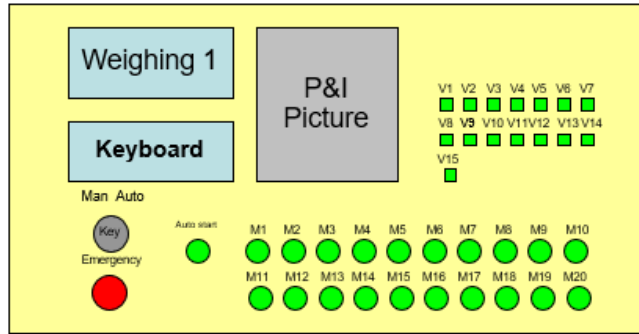

3 in 1 Coffee & Others Powder Processing Guide

3 in 1 Coffee Powder Mix Processing System / 2013

Saralee (Thailand) Co.,Ltd (JDE Group) / Moccona Coffee



The powder handling system consisting of :

- 4 of Big Bag Unloading stations , Coffee, Non Dairy creamer, Sugar & Milk
- 4 of Dosing Screw Conveyor
- 4 of Weighting Hopper with Load cell set
- 1 of Dust collecting system

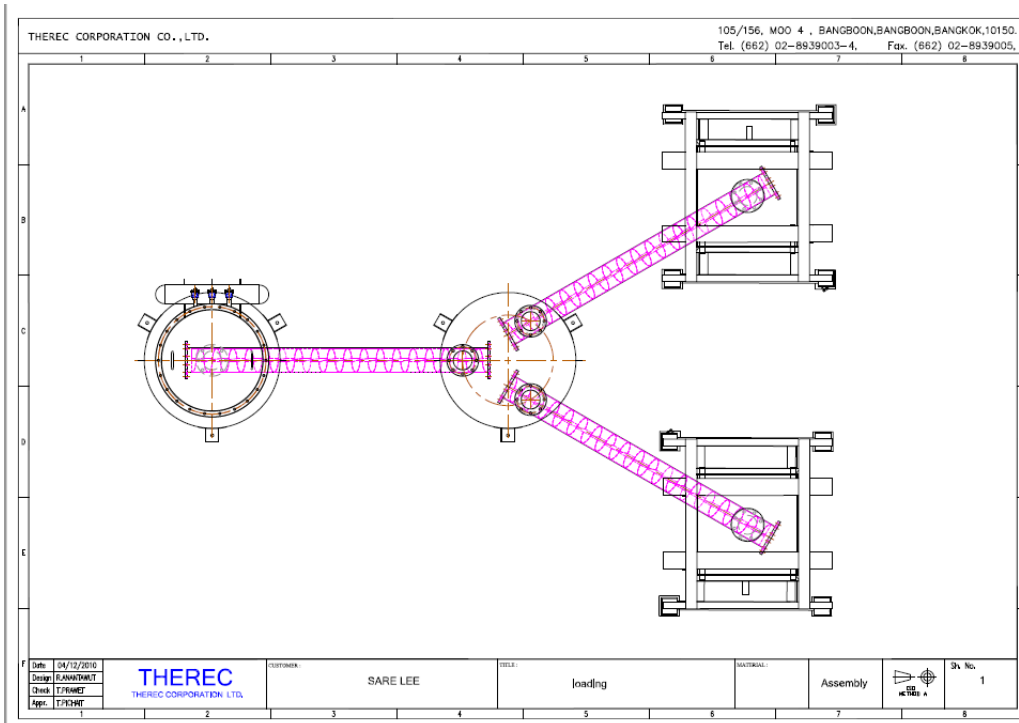



INTERIOR FINISHED SCHEDULE





FLOOR

-  ชั้น PU หนา 8 มม.
-  ชั้น PU หนา 4 มม.

WALL

-  หน้า METAL SHEET ZINCALUNE 0.40 มม.
-  ผนังระบบกันสาดขนาด 3"
-  ผนังระบบกันสาดขนาด 3"

CEILING

-  ฝ้าเพดานระบบกันสาดขนาด 3"
-  ฝ้าเพดานระบบกันสาดขนาด 3"
-  ฝ้าเพดานยิปซั่มขนาด หนา 9 มม. ใส่อลูมิเนียม 1-2x4
-  ฝ้าฉาบเรียบฝ้าตะกั่ว/ทึบ

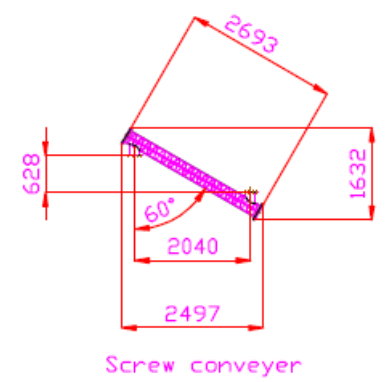
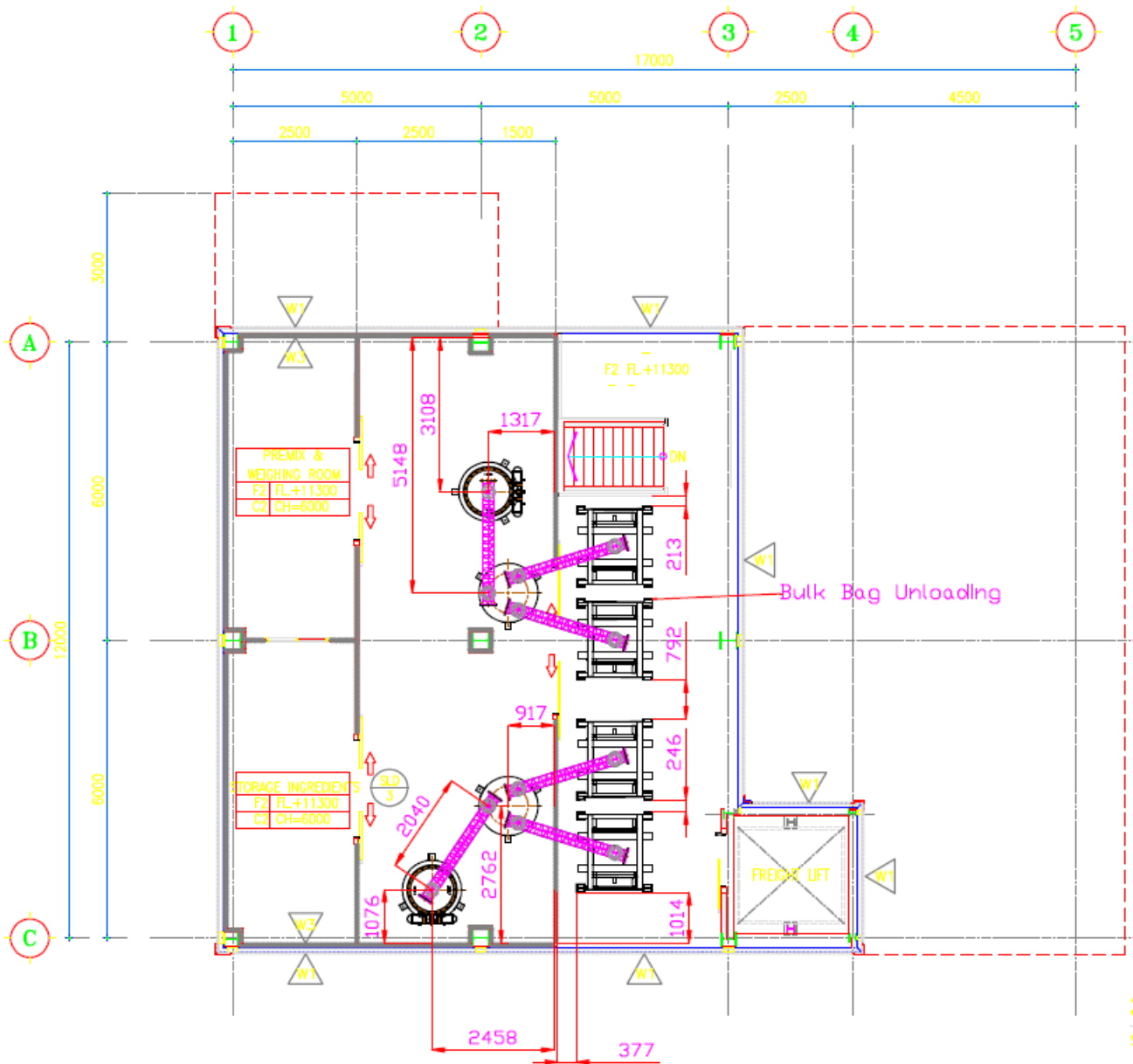

3rd FLOOR PLAN

SCALE

1 : 100



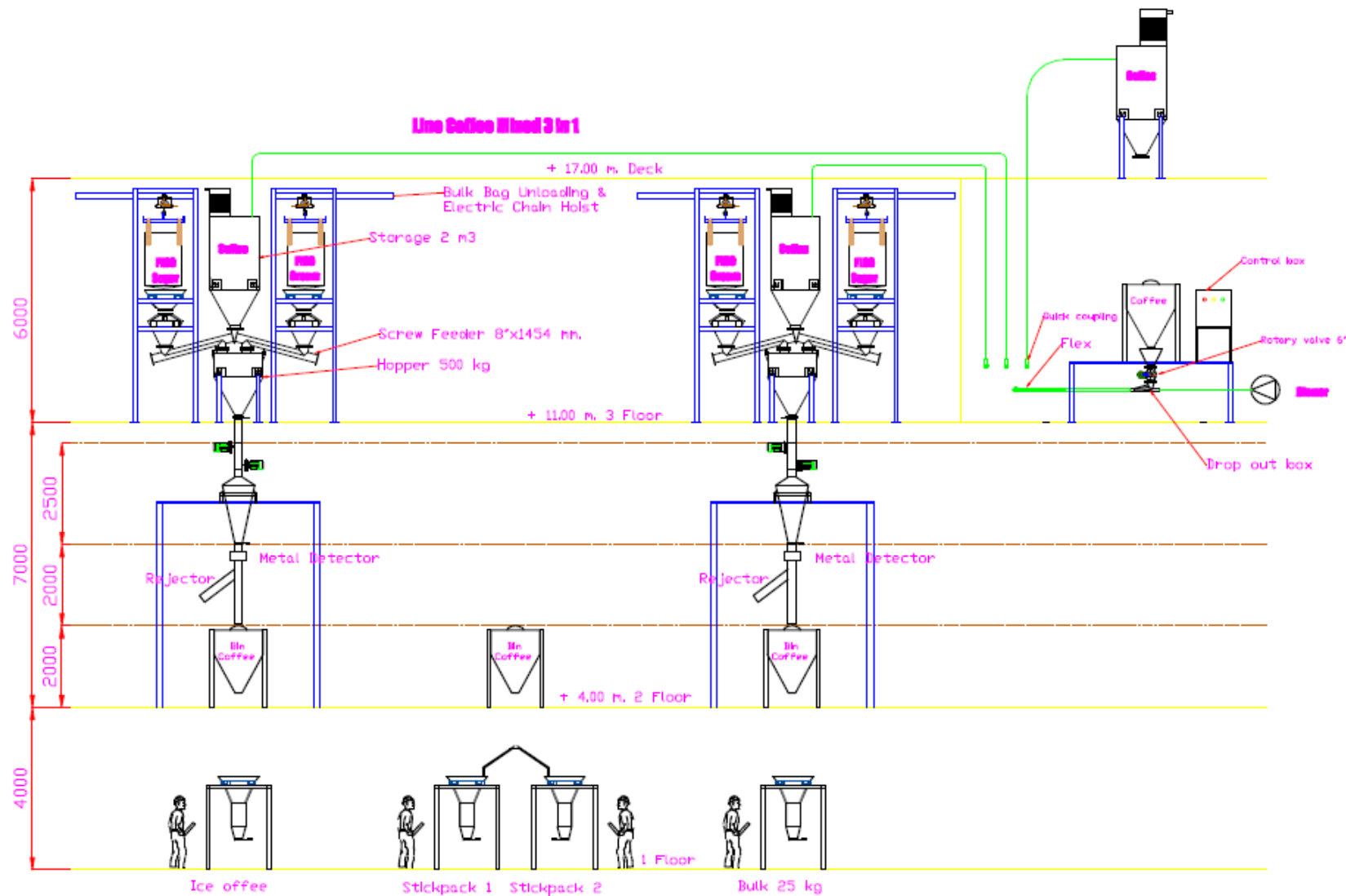

Date	8/11/2010
Design	C.SOMMAH
Check	T.PRAWET
Appr.	T.PICHAT

THEREC
 THEREC CORPORATION LTD.

CUSTOMER:

SARA LEE

TITLE:

Pneumatic Conveying System

MATERIAL:

UNITS

mm.

SCALE

Assembly



Sh. No.

1



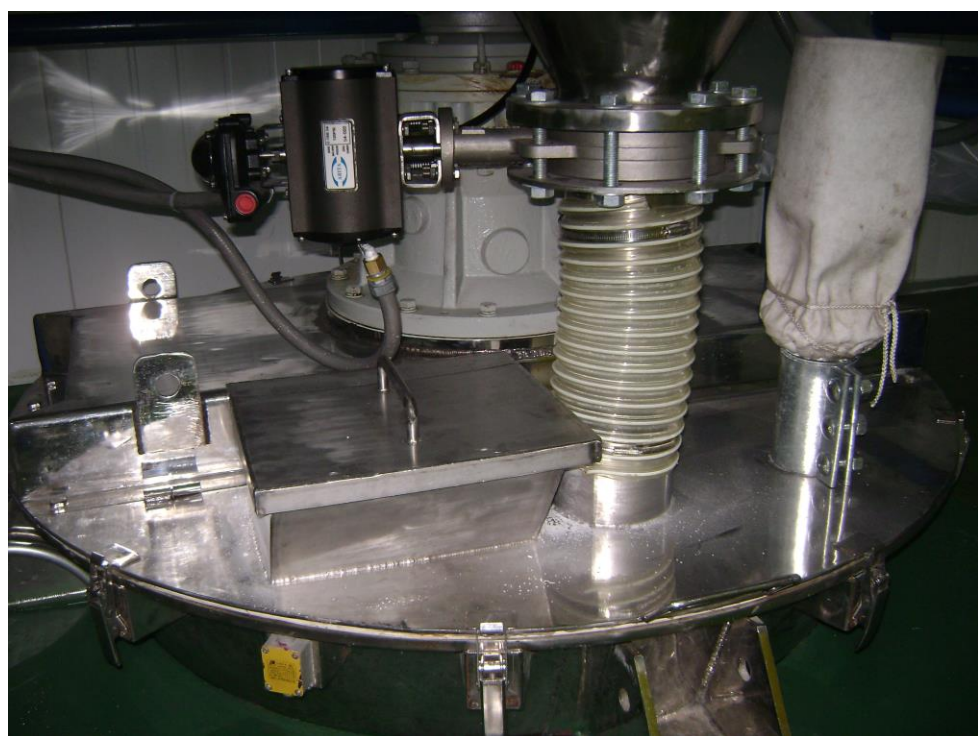

3 in 1 Coffee Powder Mix Processing System / 2007



Ciphona Coffee Co.,Ltd

The powder handling system consisting of :

- 2 of Small Bag Dumping Stations , Coffee, Non Dairy creamer, Sugar
- 1 of Ribbon Powder Mixer
- 1 of Cyclone Collector
- 1 of Dust collecting system
- 1 of Ring Blower 4.0 kw
- 1 of Rotary valve 6.0''

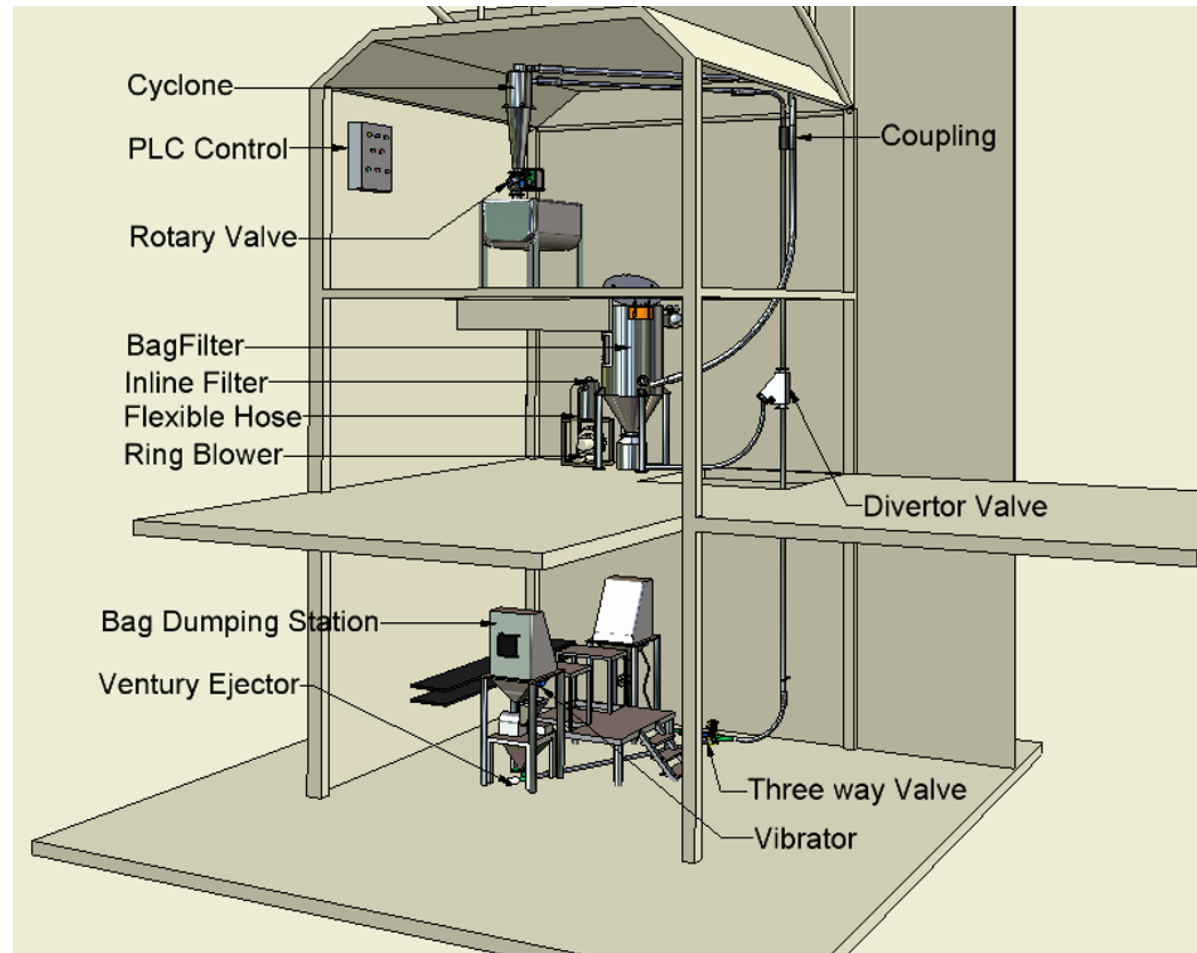
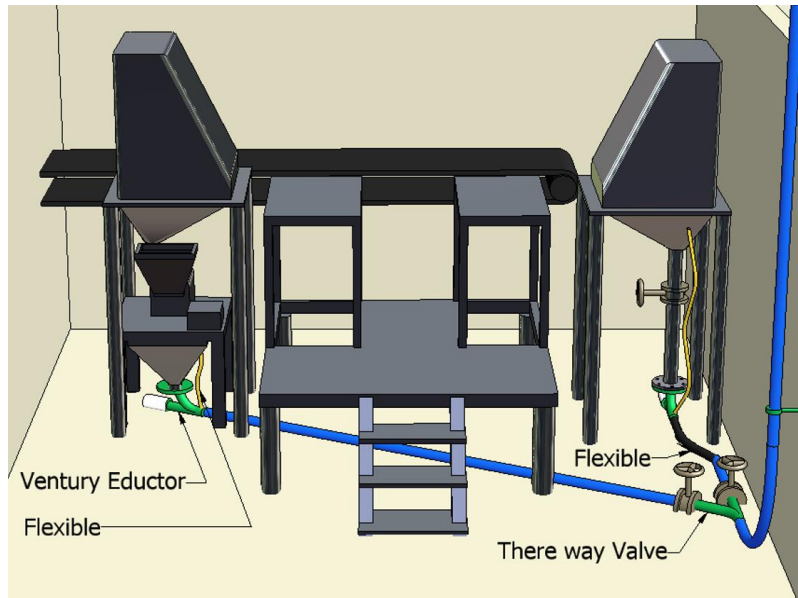





3 in 1 Coffee Powder Mix Processing System / 2018

SCML(Thailand) Co.,Ltd (JDE Group) / Moccona & Supper Coffee

The powder handling system consisting of :

- 4 of 3 in 1 Ready mix tote bin unloading station
- 1 of Pneumatic conveying system
- 1 of Food grade easy clean bag filter
- 1 of High vacuum booster blower
- 1 of 0.5 kg bag filling machine set

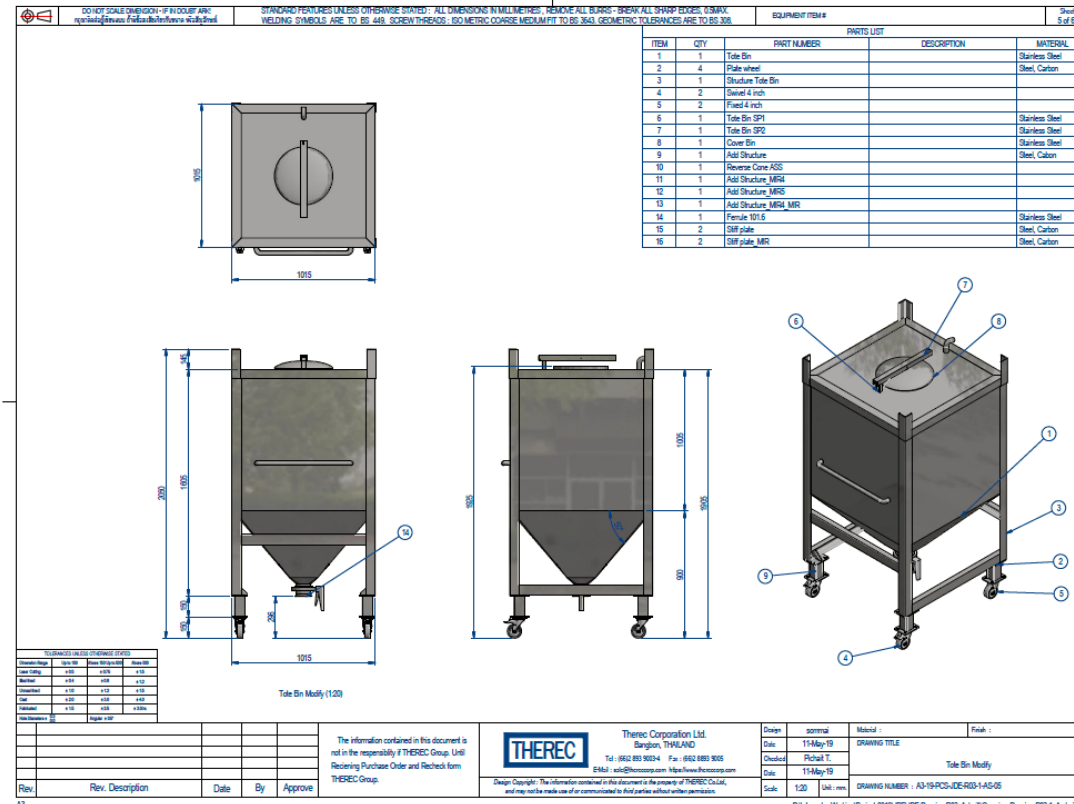
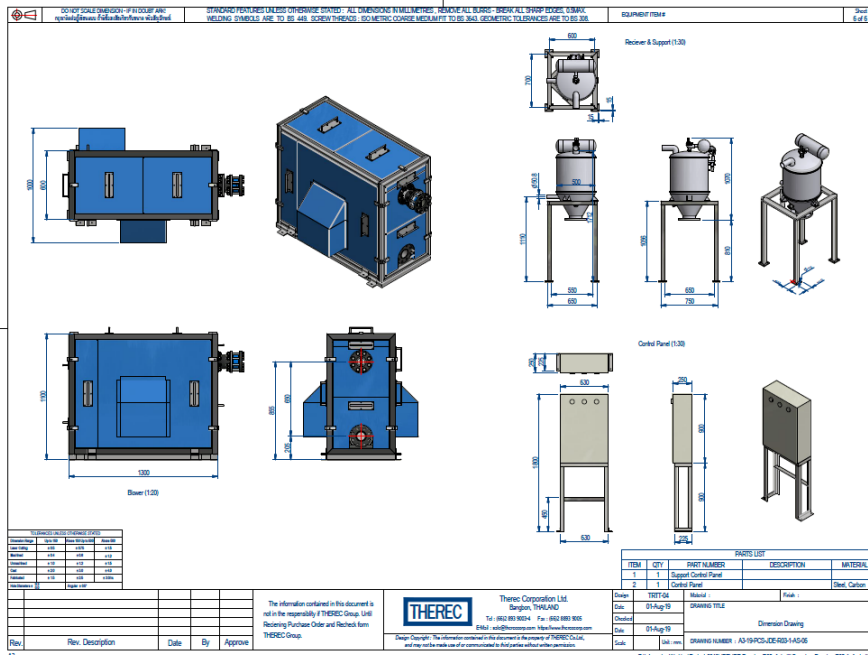

EQUIPMENT NO.
TAG NO.

SCOPE OF WORK

- THEREC SUPPLY
- EXISTING/NOT SUPPLY
- NOTIFY/INSTALLATION

DESIGN SYSTEM

Project name : Pneumatic Conveying System
 Product name : Three in one coffee
 Particle Size : 100 micron
 Bulk Density : 1g/cm³
 Pneumatic conveyor Capacity : 1,500 kg/hr.
 Total Distance : 14 m
 Total Height : 6 m
 Number of pipe bend : 3 Pcs

NO.	EQUIPMENT	DESCRIPTION	QTY
101	AIR INLET FILTER	SUS304	1
102	TIE ROD	Existing / Modify Structure	1
103	WELDING HEAD	SUS304	1
104	DRIP OUT BOX	SUS304, TMSV27	1
105	PIPING JOINT	SUS316, Indent Pipe, 2" Feed grade	1
106	HEAVY DUTY HOSE	SUS304, Indent Pipe, 2" Feed grade	1
107	DIFFERENTIAL PRESSURE GAUGE	Transmitter	1
108	BUTTERFLY VALVE	SUS304, Indent Pipe, 2" Feed grade	1
109	FLY WHEEL	Scope of Confirmation	1
110	LEVEL SWITCH	Volume Filling, 4-11 Level	2
111	PIPING JOINT	SUS304, Indent Pipe, 3" Feed grade	1
112	FLY WHEEL	Scope of Confirmation	1
113	VACUUM SWITCH	Scope of Confirmation	1
114	VACUUM GAUGE	Scope of Confirmation	1
115	VACUUM RELEASE VALVE	Scope of Confirmation	1
116	VALVE	Scope of Confirmation	1
117	HEAVY DUTY HOSE	Scope of Confirmation	1
118	SWING CHECK VALVE	SUS304	1
119	BUTTERFLY VALVE	2" Indent Pipe, 4-11 Level	1
120	BALL VALVE	SUS304 & Indent Pipe, 4-11 Level	2
121	HEAVY DUTY HOSE	SUS304, & Indent Pipe, 4-11 Level	1
122	CONTROL PANEL WIRING	Scope of Confirmation	1

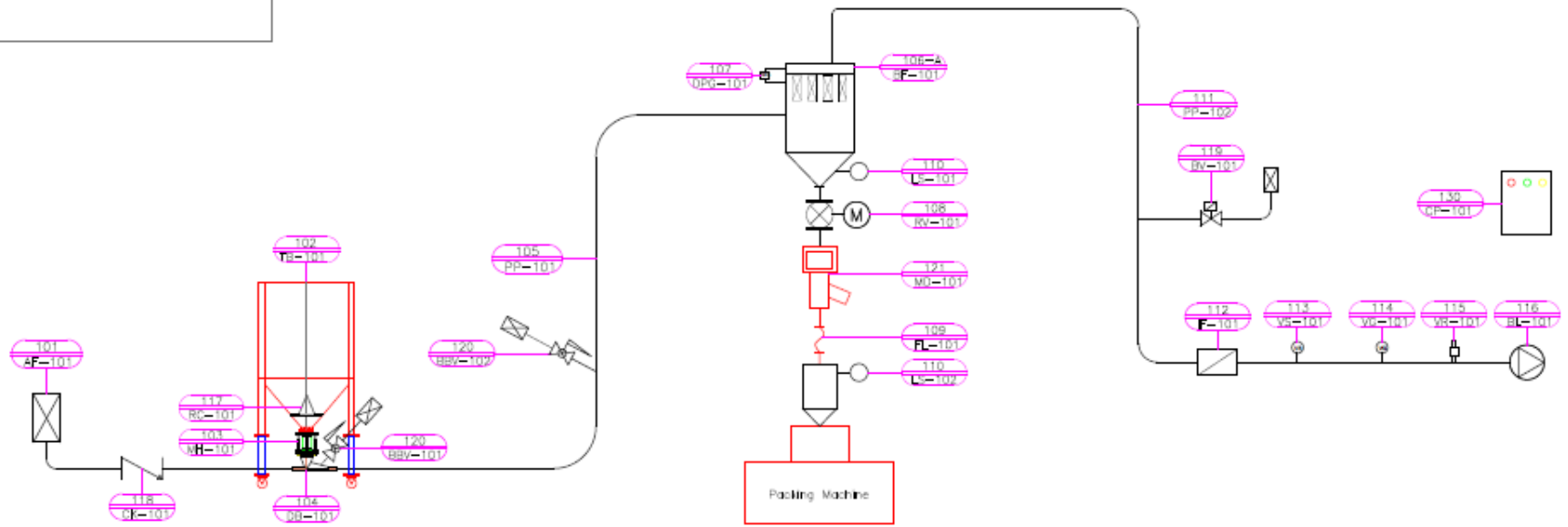

Rev.	Rev. Description	Date	By	Approve
01	Add Ball Valve & Butterfly Valve	27 JAN 20	Somchai C.	Pichak T.



Therec Corporation Ltd.
 Bangkok, THAILAND
 Tel : (662) 883 8034 Fax : (662) 883 8035
 E-Mail : sales@therec.com <http://www.therec.com>

Design	Somchai C.	Material	Contact part : SUS	Finish	
Date	18 APR 2019	DRAWING TITLE			
Checked	Pichak T.	Pneumatic Conveying System : 1,500 kg/hr P&ID			
Date		DRAWING NUMBER : A3-19-SCML-PCS-P&ID-R01			
SCALE	As Scale				

Design Copyright : The information contained in this document is the property of THEREC Co.Ltd., and may not be made use of or communicated to third parties without written permission.



DO NOT SCALE DIMENSION - IF IN DOUBT ASK
อย่าวัดขนาดจากรูป - ถ้าไม่แน่ใจถามผู้ร่าง

STANDARD FEATURES UNLESS OTHERWISE STATED: ALL DIMENSIONS IN MILLIMETRES. REMOVE ALL BURRS - BREAK ALL SHARP EDGES, 0.5MAX.
คุณสมบัติมาตรฐาน เว้นแต่จะระบุไว้เป็นอย่างอื่น: ทุกขนาดเป็นมิลลิเมตร. กำจัดครีบก้น - ทำมุมแหลมให้เรียบร้อย, 0.5MAX.
WELDING SYMBOLS ARE TO BS 449. SCREW THREADS: ISO METRIC COARSE MEDIUM FIT TO BS 3643. GEOMETRIC TOLERANCES ARE TO BS 308.

EQUIPMENT ITEM#

Sheet
1 of 6

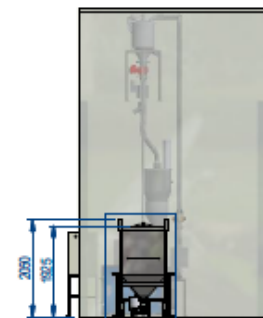
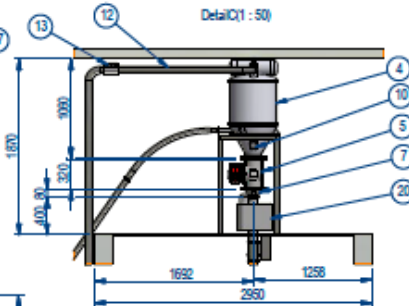
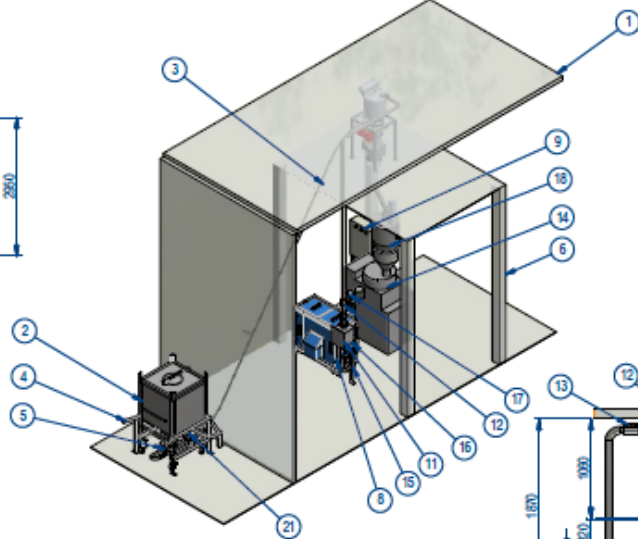
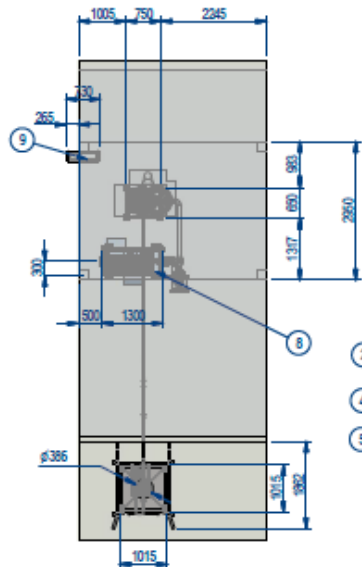

Detail B

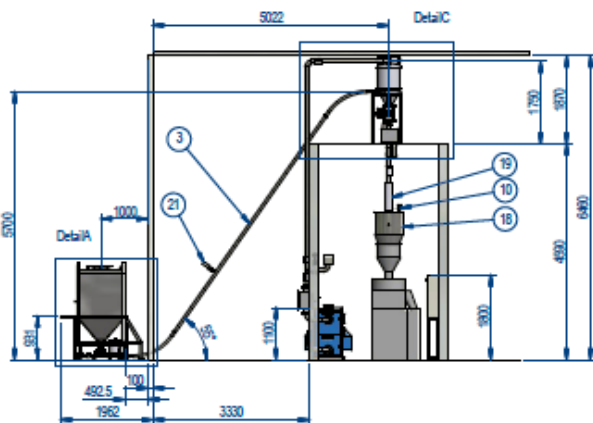

Overview Drawing (1 : 100)

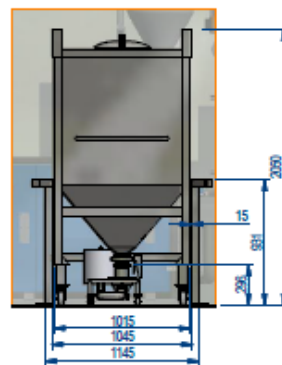

Detail B (1 : 35)

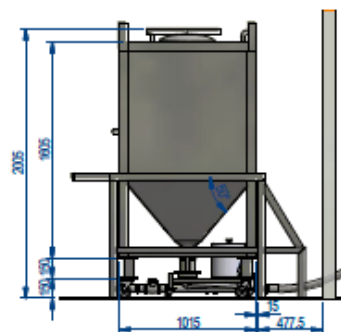

Detail A (1 : 35)

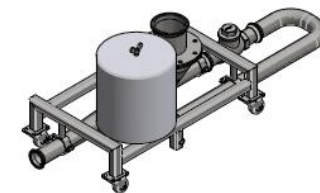

		PARTS LIST		
ITEM	QTY	PART NUMBER	DESCRIPTION	MATERIAL
1	1	Warehouse		Generic
2	1	Tote Bin Ass	Modify	
3	1	Piping Product	2' Food grade	
4	1	Structure Stopper		
5	1	Inlet Product Set		
6	1	Structure of Receiver		Generic
7	1	Reduce under rotary valve		Stainless Steel
8	1	Blower Package NB80		
9	1	Control Panel Ass		
10	2	Level UWT 4020		Generic
11	1	Inline Strainer 3 in Tube		
12	1	Piping Receiver to Blower		
13	4	Coupling 3 in-3C Tube Ass		
14	1	Packing Machine		Generic
15	1	Piping Blower to Air		
16	1	Vacuum Switch		Generic
17	1	Butterfly Valve 2.5 in Auto		
18	1	Buffer Hopper_Ass		
19	1	Vent Filter		Generic
20	1	Metal detector Ass Ass		
21	2	Ball Valve 1.2 & Filter		

TOLERANCES UNLESS OTHERWISE STATED			
Dimension Range	Up to 300	Over 300 up to 500	Over 500
Linear Calling	+0.05	+0.10	+0.15
Bores	+0.04	+0.08	+0.12
Threads	+0.10	+0.12	+0.15
Flat	+0.02	+0.03	+0.04
Perpendicular	+0.10	+0.15	+0.20
Surface Finish	Rough as 10'		

Rev.	Rev. Description	Date	By	Approve

The information contained in this document is not in the responsibility of THEREC Group, until Receiving Purchase Order and Recheck form THEREC Group.



Therec Corporation Ltd.
Bangkok, THAILAND

Tel : (662) 893 9034 Fax : (662) 893 9005
E-Mail : sales@therecorp.com <http://www.therecorp.com>

Design Copyright : The information contained in this document is the property of THEREC Co.Ltd, and may not be made use of or communicated to third parties without written permission.

Design	Somjai C.	Material :	Finish :
Date	21-Sep-19	DRAWING TITLE	
Checked	Pichai T.	Overview Drawing 01	
Date	21-Sep-19	DRAWING NUMBER : A3-19-PCS-JE-R03-1-AS-01	
Scale	1 : 80	Unit :	mm.

26 JAN 2020







JDE
JACOBS DOUWE EGBERTS





3 in 1 Cacao Powder Mix Processing System / 2021

AB Food Co.,Ltd. / Ovaltine 2012 to 2021



The powder handling systems consisting of :

- 4 of Pneumatic conveying systems
- 12 of Food grade easy clean bag filters
- 4 of High vacuum booster pump
- 8 of Food grade easy clean rotary valve
- 1 of Big bag & Tote Bin unloading station
- 5 of Food grade easy clean screw conveyors

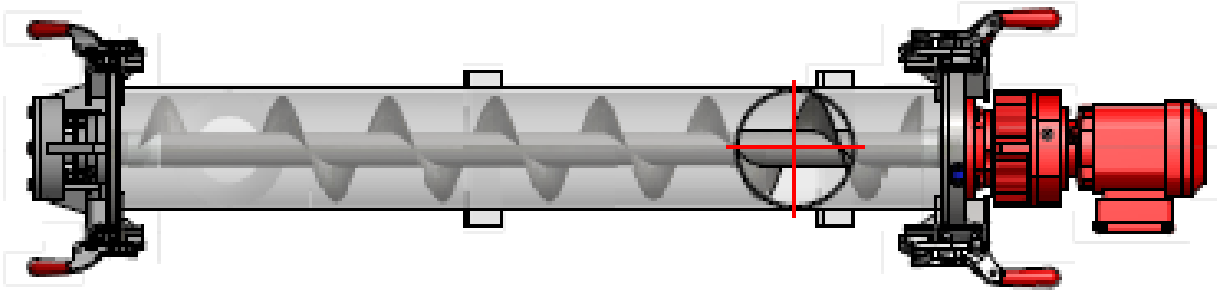



DO NOT SCALE DIMENSION - IF IN DOUBT ASK!
 มิใช่การวัดขนาดเพื่อใช้สร้างงาน

STANDARD FEATURES UNLESS OTHERWISE STATED : ALL DIMENSIONS IN MILLIMETRES , REMOVE ALL BURRS - BREAK ALL SHARP EDGES, 0.5MAX.
 WELDING SYMBOLS ARE TO BS 449. SCREW THREADS : ISO METRIC COARSE MEDIUM FIT TO BS 3643. GEOMETRIC TOLERANCES ARE TO BS 308.

EQUIPMENT ITEM #

Weight N/A

Sheet
1 of 4

Pneumatic Conveyor System

Customer : AB FOOD THAILAND

Project : BD 1,2,3

(Drawing for Review Not use for Construction)

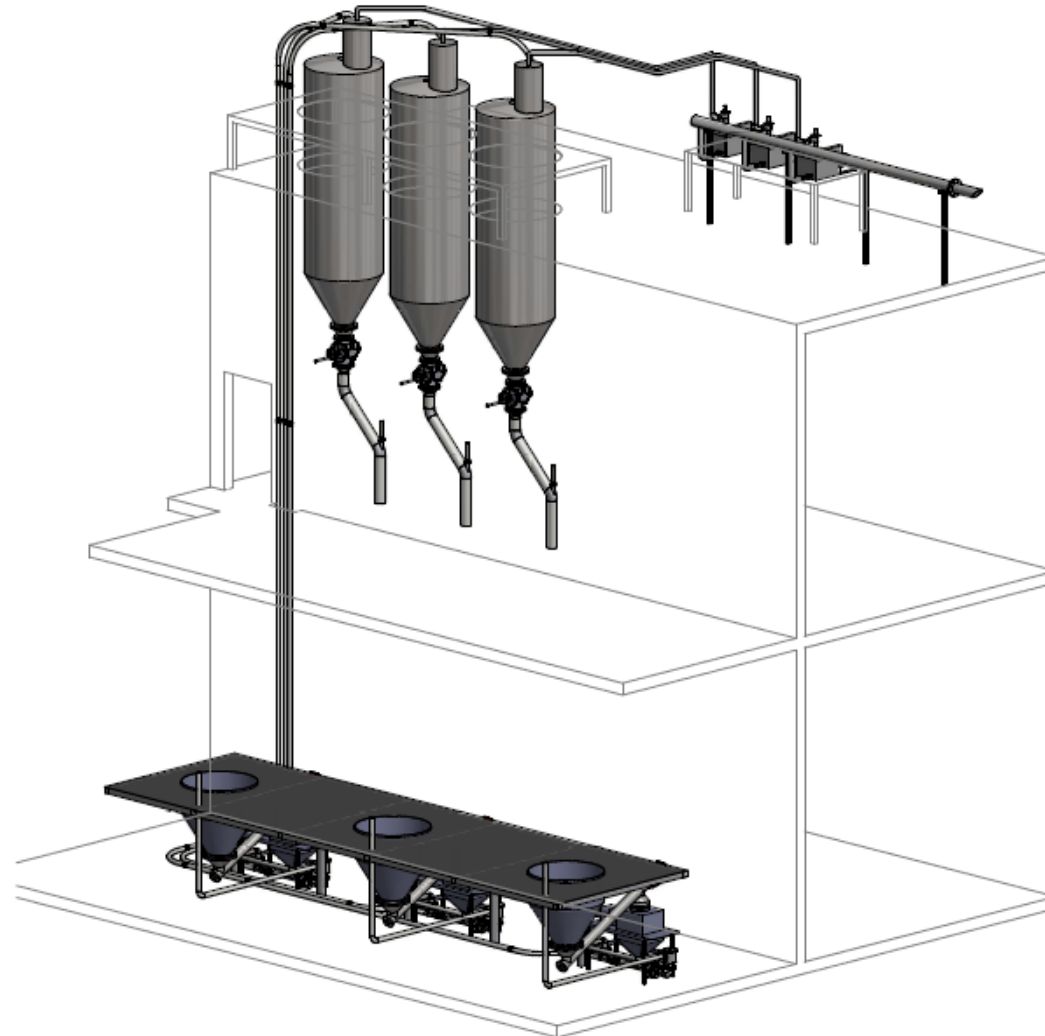

TOLERANCES UNLESS OTHERWISE STATED			
Dimension Range	Up to 300	From 300 Up to 500	Above 500
Linear Cutting	±0.1	±0.15	±0.2
Machined	±0.1	±0.15	±0.2
Threaded	±0.1	±0.15	±0.2
Cast	±0.2	±0.3	±0.4
Welded	±1.0	±1.5	±2.0mm
File Dimension	±0.1	Angle ±0.1°	

Reference P&ID No. APP15-003-PID-06

Rev.	Rev. Description	Date	By	Approve

The information contained in this document is not in the responsibility of THEREC Group. Until Receiving Purchase Order and Recheck form THEREC Group.



Therec Corporation Ltd.
Bangkok, THAILAND

Tel : (66) 2 893 9003-4 Fax : (66) 2 893 9005
 E-Mail : sales@thereccorp.com Http://www.thereccorp.com

Design Copyright: The information contained in this document is the property of THEREC Co.Ltd, and may not be made use of or communicated to third parties without written permission.

Design	Nuttapong.S	Material :	Finish :
Date	08-May-15	DRAWING TITLE Pneumatic Conveyor System	
Checked		Drawing for Review Not use for Construction	
Date	08-May-15	DRAWING NUMBER :	
Scale		Unit : mm	

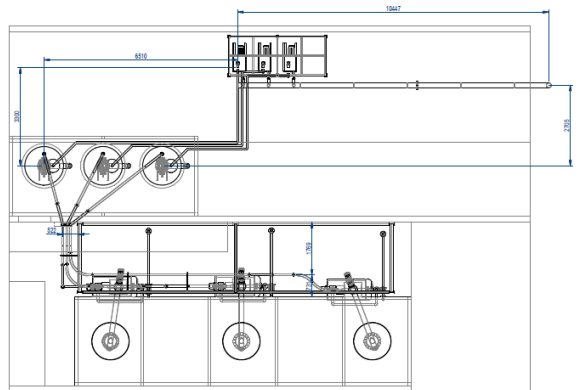

Rev.	Rev. Description	Date	By	Approve	PROJECT	80133 20146

Customer:	AB Food & Beverage (Thailand) Ltd.
Customer Logo:	
Customer Name:	Therac Corporation Ltd.
Customer Address:	Bangkok, THAILAND
Customer Tel:	Tel: +662 893 9024
Customer Fax:	Fax: +662 899 9005
Customer Email:	E-Mail: sales@therac.com, thailand@therac.com
Customer Website:	Website: www.therac.com
Customer Logo:	
Customer Name:	Therac Corporation Ltd.
Customer Address:	Bangkok, THAILAND
Customer Tel:	Tel: +662 893 9024
Customer Fax:	Fax: +662 899 9005
Customer Email:	E-Mail: sales@therac.com, thailand@therac.com
Customer Website:	Website: www.therac.com
Customer Logo:	
Customer Name:	Therac Corporation Ltd.
Customer Address:	Bangkok, THAILAND
Customer Tel:	Tel: +662 893 9024
Customer Fax:	Fax: +662 899 9005
Customer Email:	E-Mail: sales@therac.com, thailand@therac.com
Customer Website:	Website: www.therac.com

Design Copyright: The information contained in this document is the property of THEREC Co., Ltd. and may not be made use of or communicated to third parties without our written permission.

D:\Nulapong Work\Customer\AB Food\2014\vacuum System 801.2.30\Drawing\RD3 Pipe Route.dwg

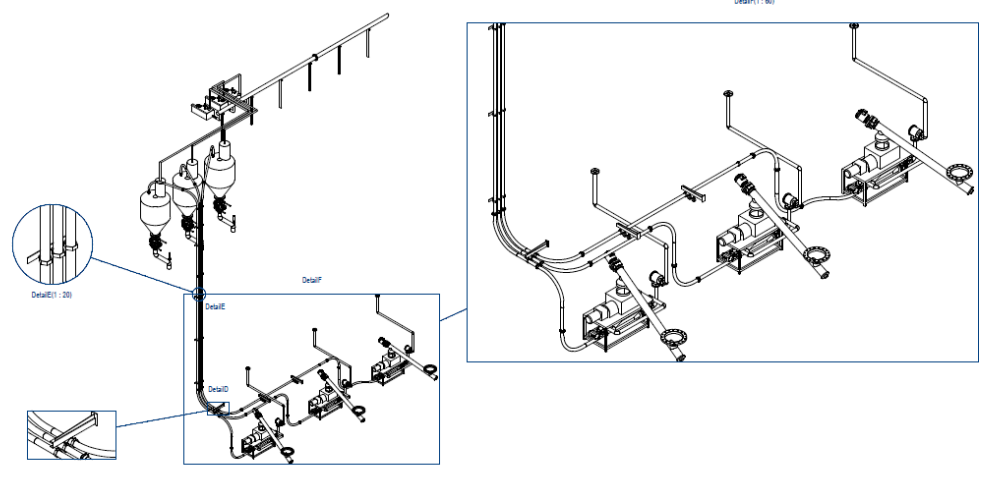

Rev.	Rev. Description	Date	By	Approve	PROJECT	80133 20146

Customer:	AB Food & Beverage (Thailand) Ltd.
Customer Logo:	
Customer Name:	Therac Corporation Ltd.
Customer Address:	Bangkok, THAILAND
Customer Tel:	Tel: +662 893 9024
Customer Fax:	Fax: +662 899 9005
Customer Email:	E-Mail: sales@therac.com, thailand@therac.com
Customer Website:	Website: www.therac.com
Customer Logo:	
Customer Name:	Therac Corporation Ltd.
Customer Address:	Bangkok, THAILAND
Customer Tel:	Tel: +662 893 9024
Customer Fax:	Fax: +662 899 9005
Customer Email:	E-Mail: sales@therac.com, thailand@therac.com
Customer Website:	Website: www.therac.com

Design Copyright: The information contained in this document is the property of THEREC Co., Ltd. and may not be made use of or communicated to third parties without our written permission.

D:\Nulapong Work\Customer\AB Food\2014\vacuum System 801.2.30\Drawing\RD3 Pipe Route.dwg

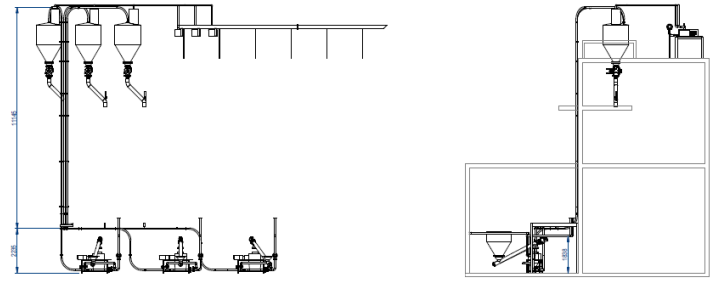

Rev.	Rev. Description	Date	By	Approve	PROJECT	80133 20146

Customer:	AB Food & Beverage (Thailand) Ltd.
Customer Logo:	
Customer Name:	Therac Corporation Ltd.
Customer Address:	Bangkok, THAILAND
Customer Tel:	Tel: +662 893 9024
Customer Fax:	Fax: +662 899 9005
Customer Email:	E-Mail: sales@therac.com, thailand@therac.com
Customer Website:	Website: www.therac.com
Customer Logo:	
Customer Name:	Therac Corporation Ltd.
Customer Address:	Bangkok, THAILAND
Customer Tel:	Tel: +662 893 9024
Customer Fax:	Fax: +662 899 9005
Customer Email:	E-Mail: sales@therac.com, thailand@therac.com
Customer Website:	Website: www.therac.com

Design Copyright: The information contained in this document is the property of THEREC Co., Ltd. and may not be made use of or communicated to third parties without our written permission.

D:\Nulapong Work\Customer\AB Food\2014\vacuum System 801.2.30\Drawing\RD3 Pipe Route.dwg



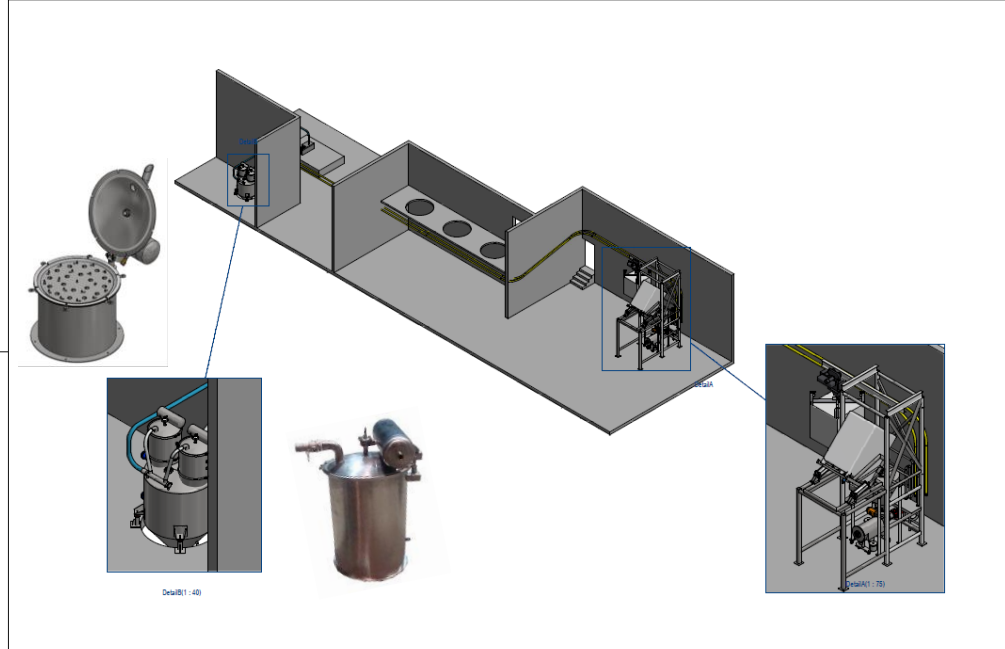

Rev	Rev. Description	Date	By	Approve

	Therec Corporation Ltd Bangkok, THAILAND Tel: +662 893 9024 Fax: +662 893 9005 Email: info@therec.com www.therec.com Design Copyright: The information contained in this document is the property of THEREC Co., Ltd. and may not be made use of or communicated to third parties without written permission.	Design: Nuttipong S Date: 22-Jun-14 Drawn: Date: Scale: DRAWING NUMBER:	Material: Finish: DRAWING TITLE: DRAWING NUMBER:
--	--	--	---

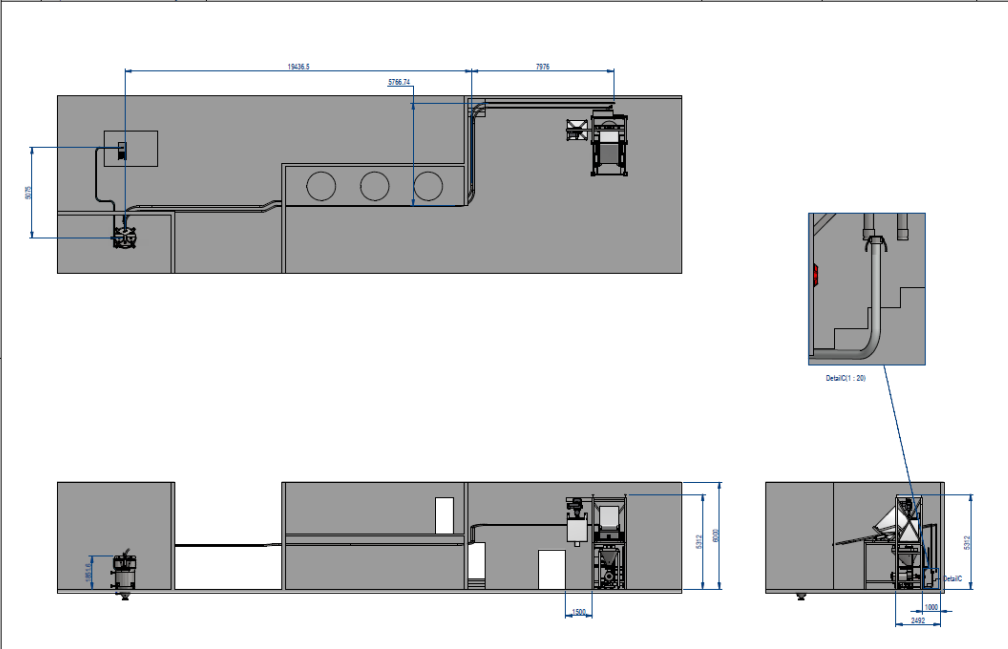

Rev	Rev. Description	Date	By	Approve

	Therec Corporation Ltd Bangkok, THAILAND Tel: +662 893 9024 Fax: +662 893 9005 Email: info@therec.com www.therec.com Design Copyright: The information contained in this document is the property of THEREC Co., Ltd. and may not be made use of or communicated to third parties without written permission.	Design: Nuttipong S Date: 22-Jun-14 Drawn: Date: Scale: DRAWING NUMBER:	Material: Finish: DRAWING TITLE: DRAWING NUMBER:
--	--	--	---

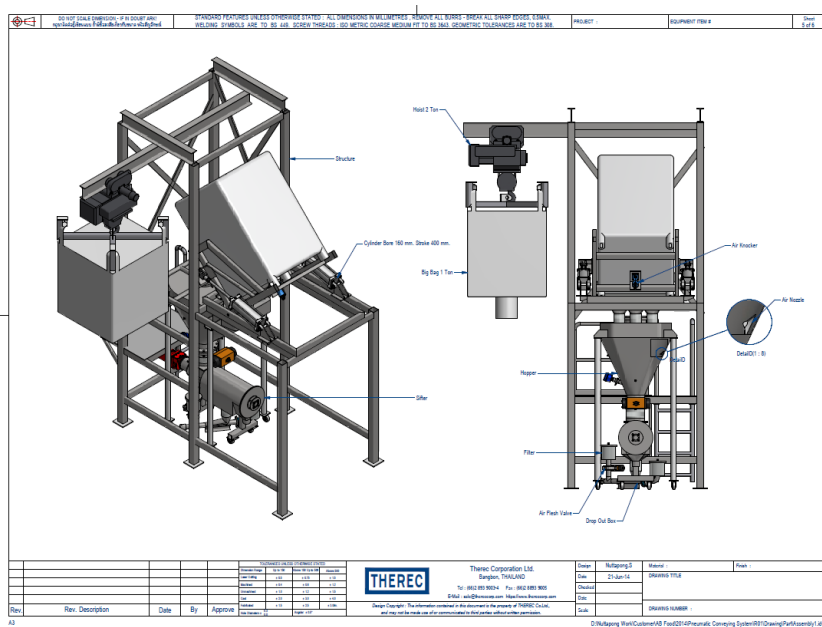
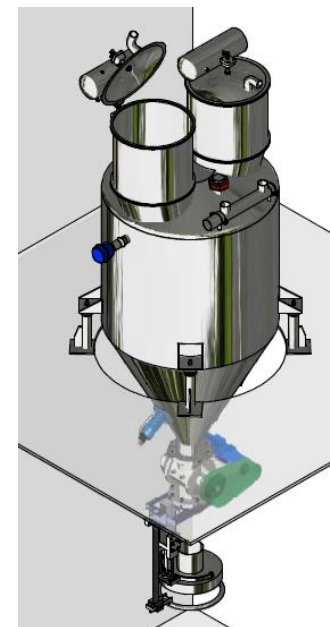

Rev	Rev. Description	Date	By	Approve

	Therec Corporation Ltd Bangkok, THAILAND Tel: +662 893 9024 Fax: +662 893 9005 Email: info@therec.com www.therec.com Design Copyright: The information contained in this document is the property of THEREC Co., Ltd. and may not be made use of or communicated to third parties without written permission.	Design: Nuttipong S Date: 23-Jun-14 Drawn: Date: Scale: DRAWING NUMBER:	Material: Finish: DRAWING TITLE: DRAWING NUMBER:
--	--	--	---





Tote Bin and Moving Head



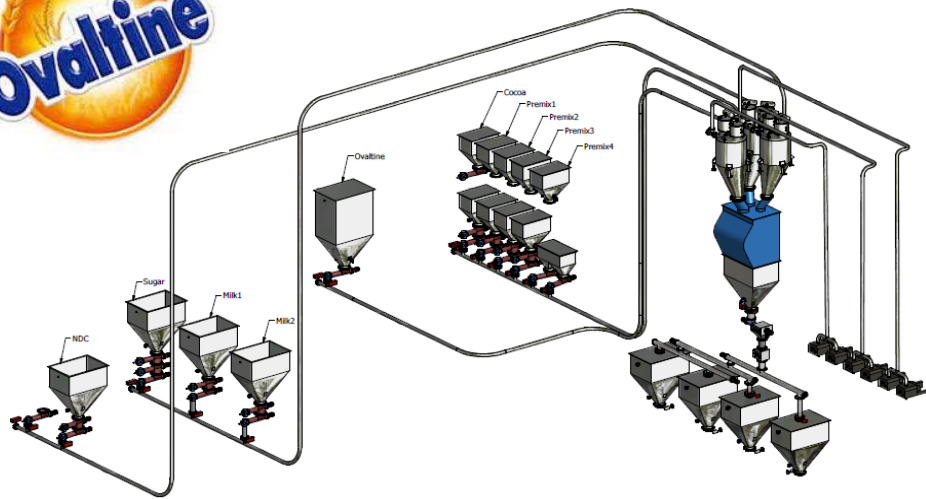

DESIGN	Plengkwan A.	27/9/2555	TITLE	
DRAWN	Huittarong S.			
QA				
APPROVED			AB Food-Dry mix	
REVISION				
NO.	C	System	REV	0
SCALE		For REC.		

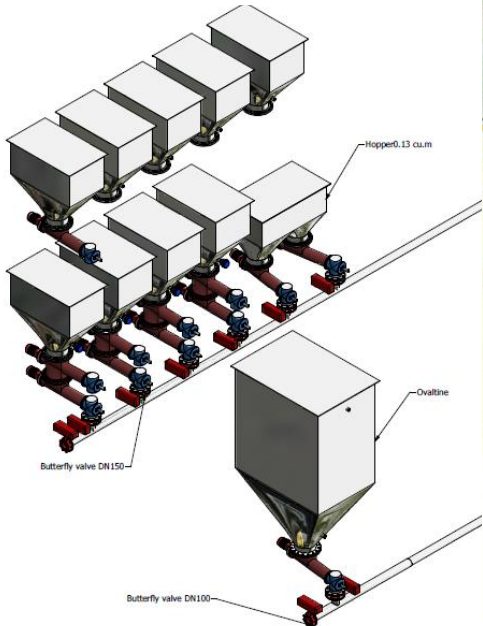
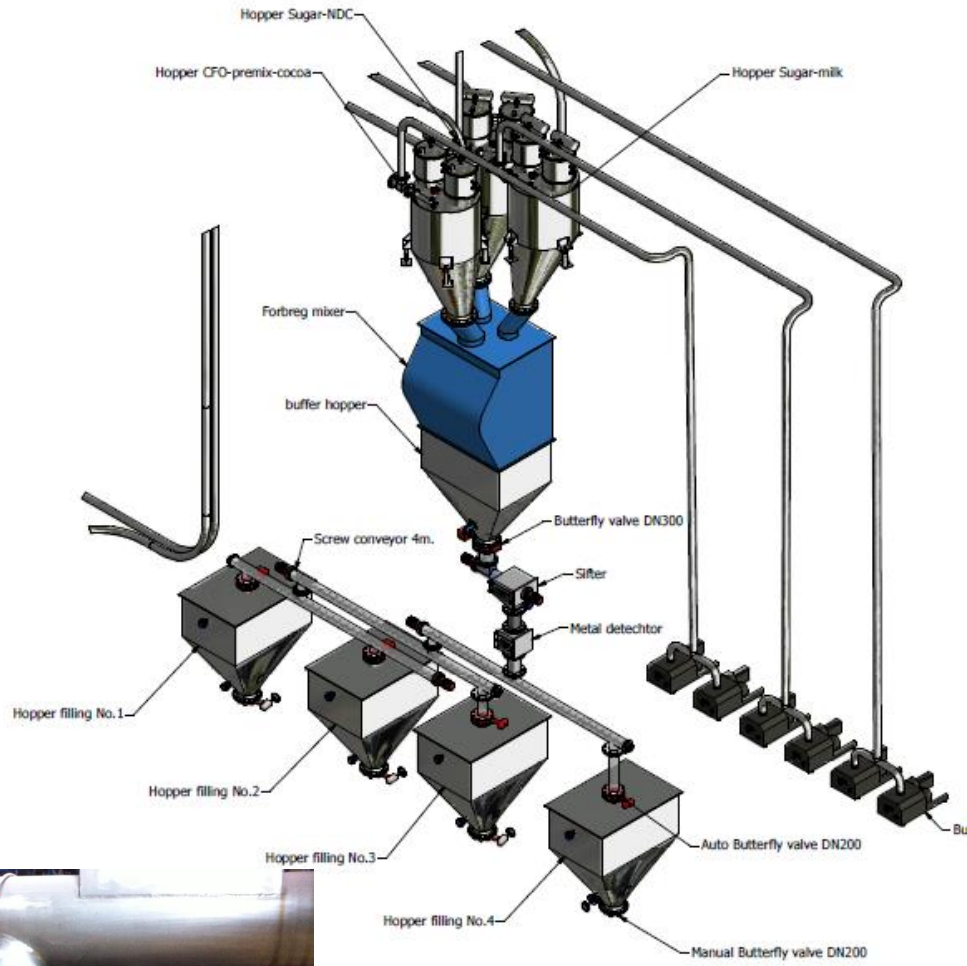

3 in 1 Coffee Powder Mix Processing System / 2019

Benjanpong Co.,Ltd (Quality Coffee Co.,Ltd's Co-packer) / Nest cafe

The powder handling system consisting of :

- 1 of Pneumatic conveying vacuum loading system
- 1 of Sugar Grinding Machine
- 1 of Dust collecting system
- 1 of Explosive Dust protection system
- 1 of Semi Auto 20 kg bag filling station

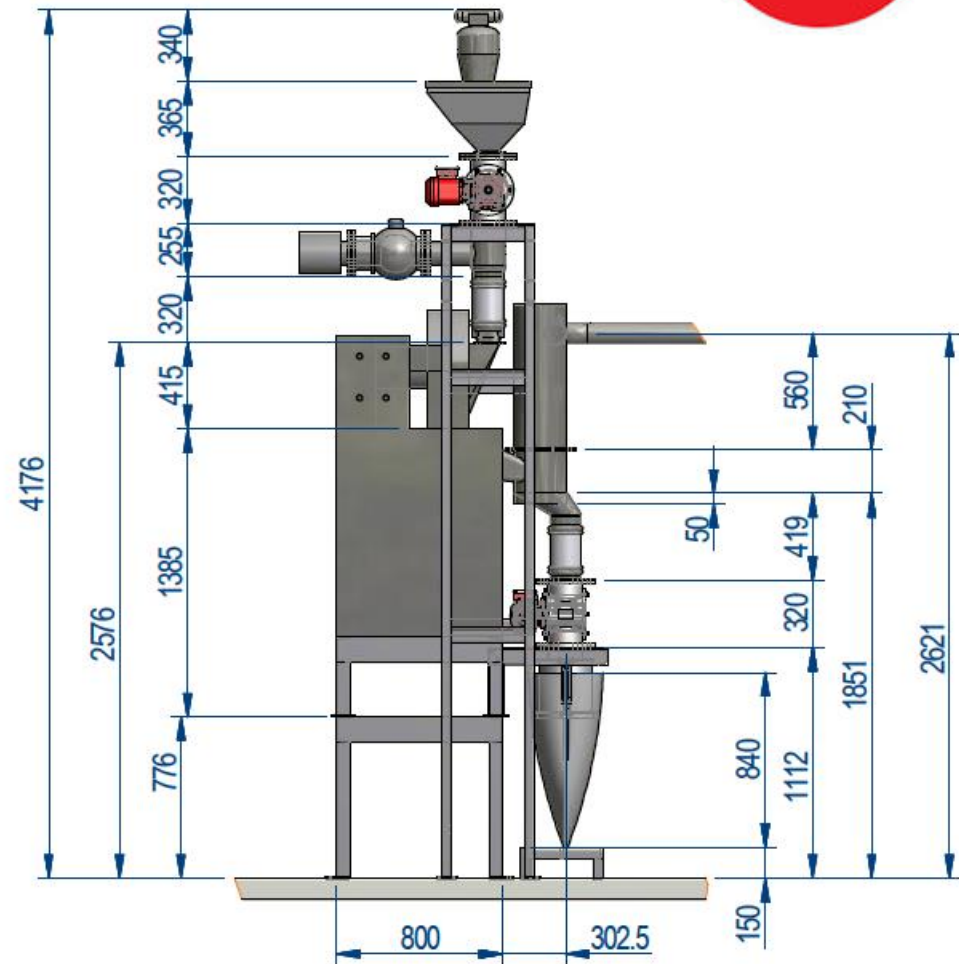
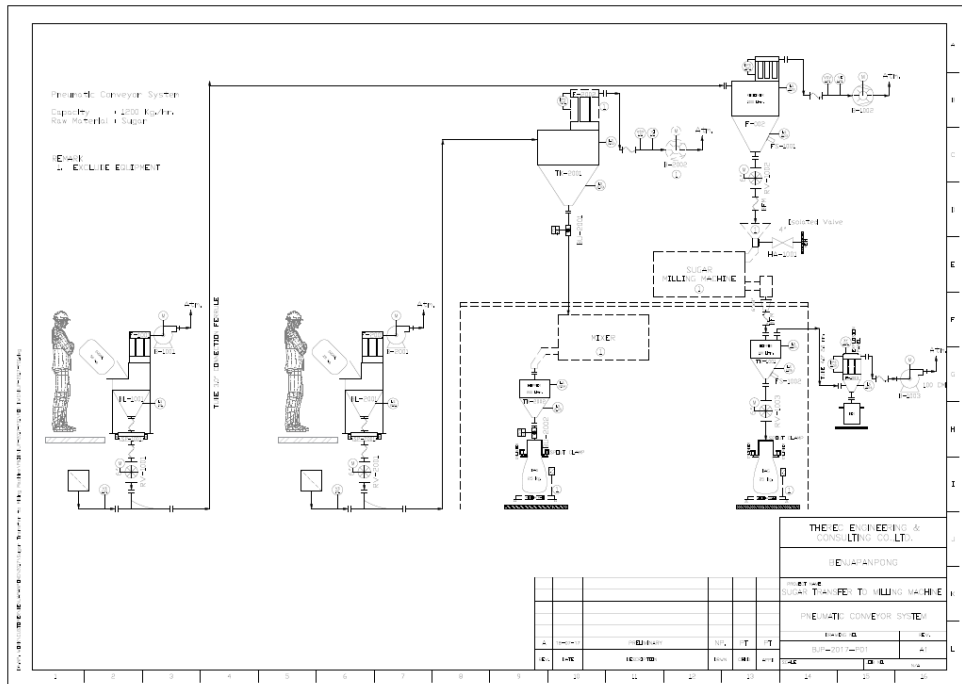

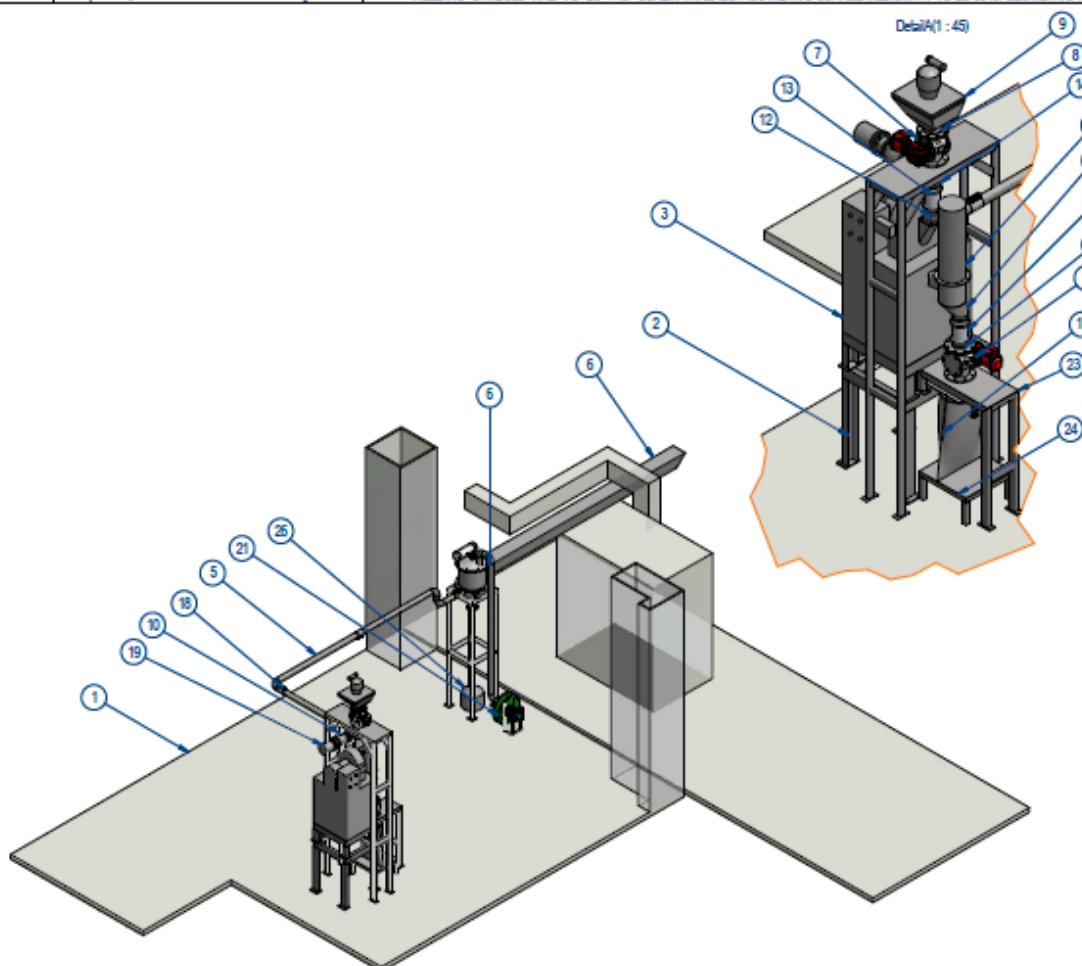

Isometric View 01 (1 : 90)

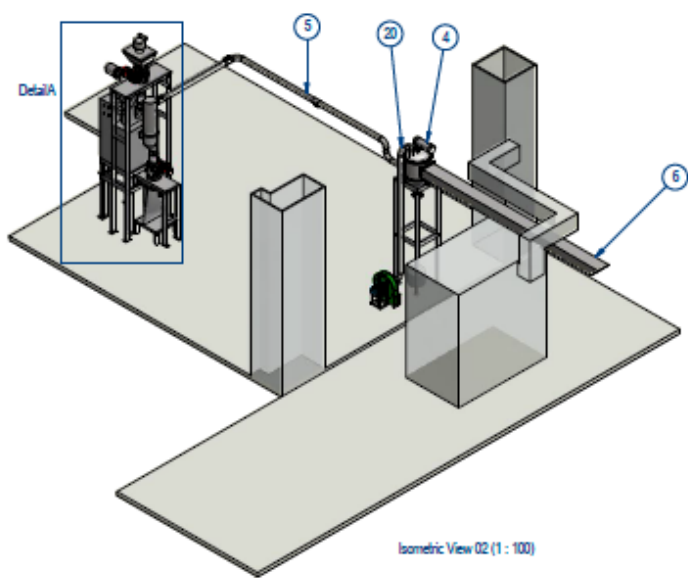

Isometric View 02 (1 : 100)

		PARTS LIST			
ITEM	QTY	PART NUMBER	DESCRIPTION	MATERIAL	
1	1	Operation room		Generic	
2	1	Mil structure_Addition		Steel	
3	1	Mil Machine Existing Ass	Existing		
4	1	Hopper receiver Ass	Structure is steel	Stainless Steel	
5	1	Piping 4 in food grade	Food grade	Stainless Steel	
6	1	Explosion and duct Ass		Steel	
7	2	TRC-150-AL-IB-D	Rotary Valve	Stainless Steel	
8	1	Reduce 6 in to existing flange 02		Stainless Steel	
9	1	Cover and Jet loader	Existing		
10	1	Float Valve Isolation		Stainless Steel	
11	1	Pipe duct dia 225 x 1000 mm		Stainless Steel	
12	1	Reduce 150 to existing flange		Stainless Steel	
13	2	BFM Spigots 150		Stainless Steel	
14	1	Three way pipe		Stainless Steel	
15	1	Reduce 255 to 150		Stainless Steel	
16	1	Flange 6 in jis 10k 6t		Stainless Steel	
17	1	Small bag	Scope of customer	Generic	
18	4	Coupling 4 in-3C tube Ass		Galvanize	
19	1	Inlet filter		Stainless Steel	
20	1	Piping outlet receiver		Stainless Steel	
21	1	CentriAss		Steel	
22	1	Spool clamp OK			
23	1	New structure 01	Structure : Steel ; Plate : Sus		
24	1	Table small bag Structure	Scope of customer	Stainless Steel	
25	1	New structure 02	Structure : Steel ; Plate : Sus		
26	1	Bin		Stainless Steel	

TOLERANCES UNLESS OTHERWISE STATED			
Dimension Range	Up to 100	From 100 to 400	Over 400
Linear Cutting	±0.15	±0.25	±0.3
Machined	±0.1	±0.15	±0.2
Unmachined	±0.2	±0.3	±0.4
Cast	±0.2	±0.3	±0.4
Forged	±0.15	±0.2	±0.25

Rev.	Rev. Description	Date	By	Approve

The information contained in this document is not in the responsibility of THEREC Group. Until Receiving Purchase Order and Recheck form THEREC Group.

THEREC
 Therac Corporation Ltd.
 Bangkok, THAILAND
 Tel : (662) 893 9034 Fax : (662) 889 9005
 Email : sales@therecorp.com https://www.therecorp.com

Design Copyright : The information contained in this document is the property of THEREC Co.Ltd, and may not be made use of or communicated to third parties without written permission.

Drawn	Sornjai C.	Material :	Finish :
Date	22-Aug-17	DRAWING TITLE	
Checked		GA Drawing : Over View drawing	
Date	22-Aug-17		
Scale	1 : 90		
DRAWING NUMBER : A3-TRE-SJP-OPTION 01-R03-P1			



Jet Loader
900 kg/hr

Rtary Valve 6"
Compact Type

Isolated Valve 4"

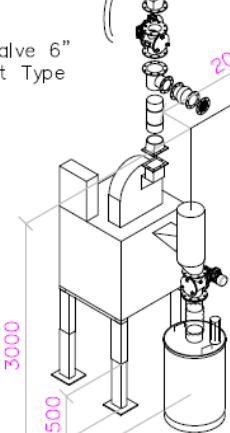

2000

6000

Rtary Valve 6"
Compact Type

Bag Filter

Explosion Panel



3500

Ring Blower

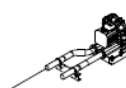

Rev.	Rev. Description	Date	BY	Approve	<p>THEREC Corporation Ltd. Bangkok, THAILAND Tel : 00662 883 9900-4 Fax : 00662 883 9903 E-Mail : info@therec.com http://www.therec.com</p> <p><small>Design Copyright © The information contained in this document is the property of THEREC Co., Ltd., and may not be made use of or communicated to third parties without written permission.</small></p>	Drawn : CHANINDIUM Date : 06/07/2017 Checked : PICHATIT Date : 06/07/2017	Model : DRAWING TITLE : ISOMETRIC VIEW	Risk : Rev. :	Rev. :
					SCALE : UNIT : mm. DRAWING NUMBER : ASTR04UFFE04-001				

